



Spec Sheet: Stainless Steel Cap (SCAP)

Features

- Strong and durable
- Variety of sizes
- Minimal upkeep over time



Dimensions (mm)

ITEM	SIZE	Ø1	Ø2	A
SCAP-018	1/8"	16.0	14.0	15.5
SCAP-014	1/4"	20.0	18.0	22.0
SCAP-038	3/8"	25.5	23.0	24.5
SCAP-050	1/2"	30.0	28.0	27.5
SCAP-075	3/4"	36.0	33.0	28.0
SCAP-100	1"	45.5	42.0	33.0
SCAP-125	1-1/4"	53.5	51.0	33.0
SCAP-150	1-1/2"	60.0	57.0	36.0
SCAP-200	2"	74.5	70.0	38.0
SCAP-250	2-1/2"	90.5	86.5	41.5
SCAP-300	3"	109.5	105.0	47.5
SCAP-400	4"	140.0	133.0	49.0

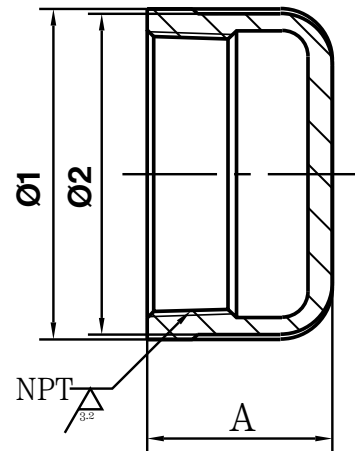

PRESSURE & TEMPERATURE RATING	
Temperature °F (°C)	Class 150,PSIG
-20 to 150 (-29 to 66)	300
200(93)	265
250 (121)	225
300(149)	185
350(177)	150

Linear dimensional tolerances for castings ISO 8062 (GB/T 6414)										
Limit deviation	Basic size segment									
	0~10	>10~16	>16~25	>25~40	>40~63	>63~100	>100~160	>160~250	>250~400	>400~630
CT8	±0.5	±0.55	±0.6	±0.65	±0.7	±0.8	±0.9	±1.0	±1.1	±1.3